

DETAIL "1"

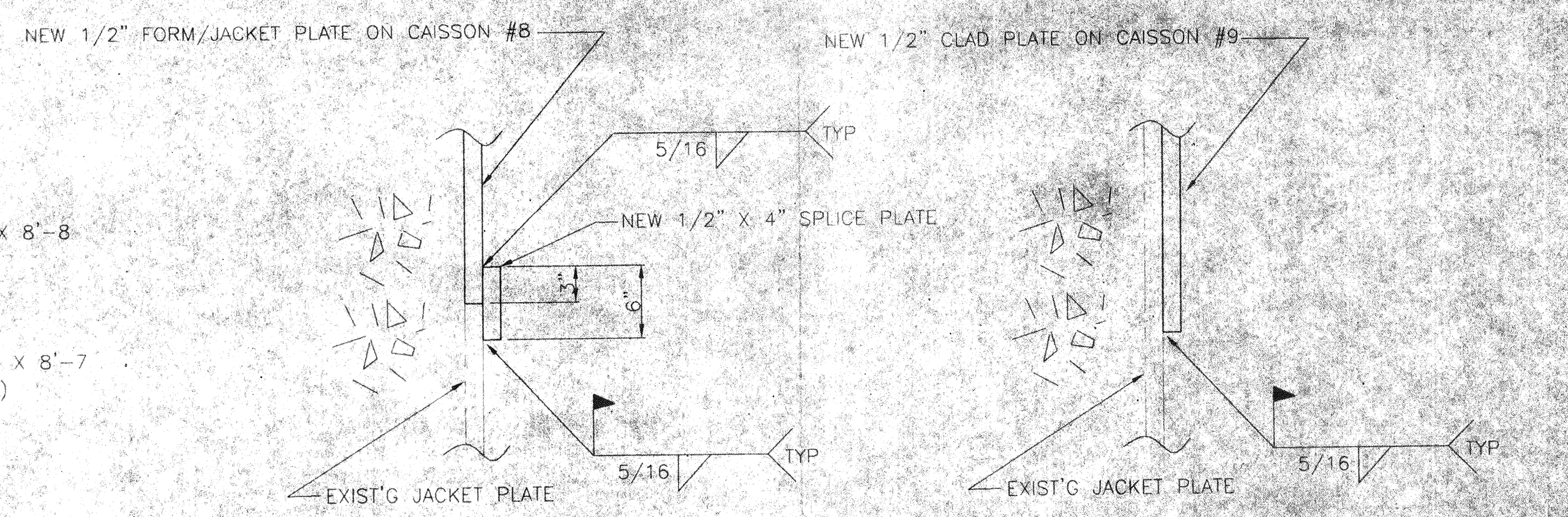

DETAIL "2"

DETAIL "3"

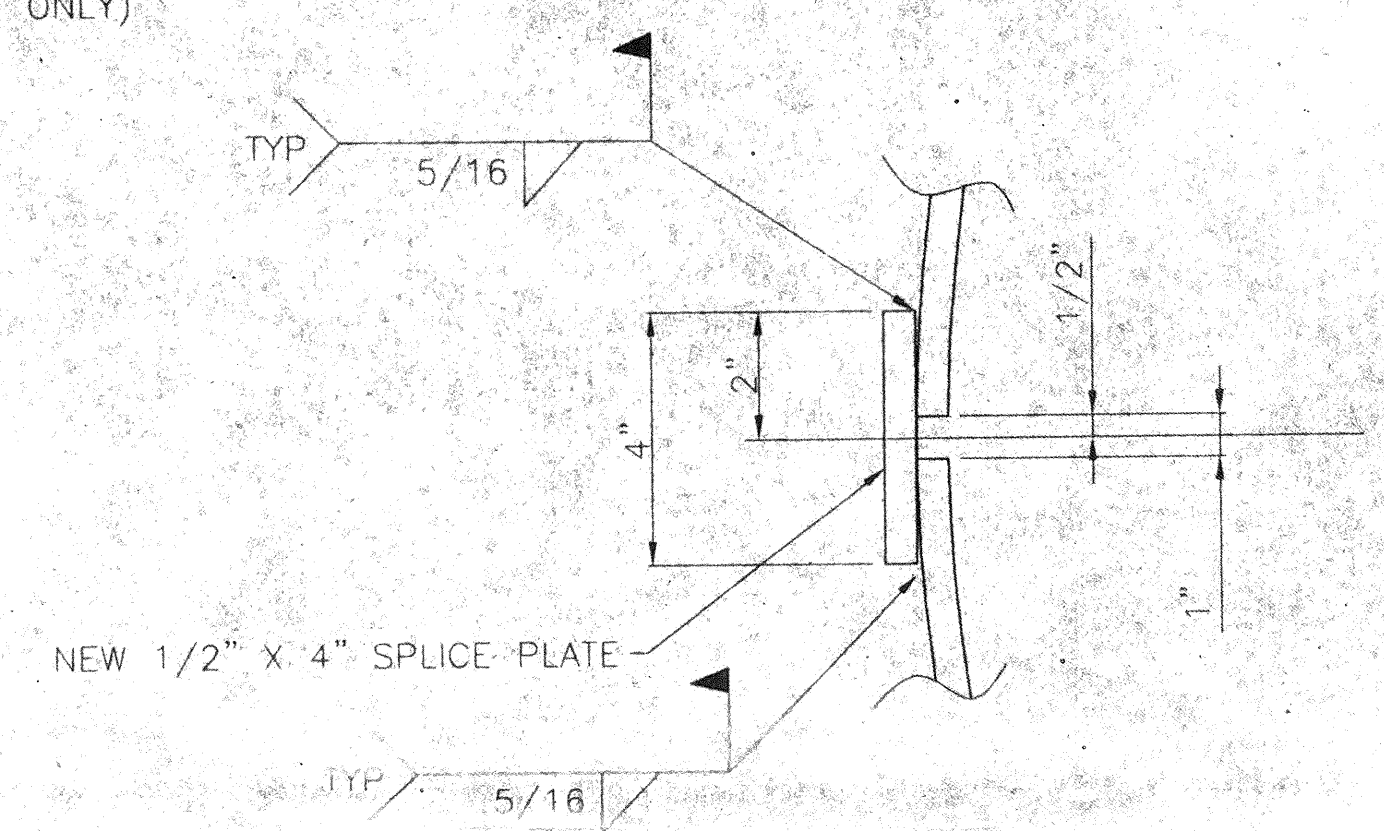

DETAIL "4" (SHOWN)

DETAIL "5" (OPP. HAND)

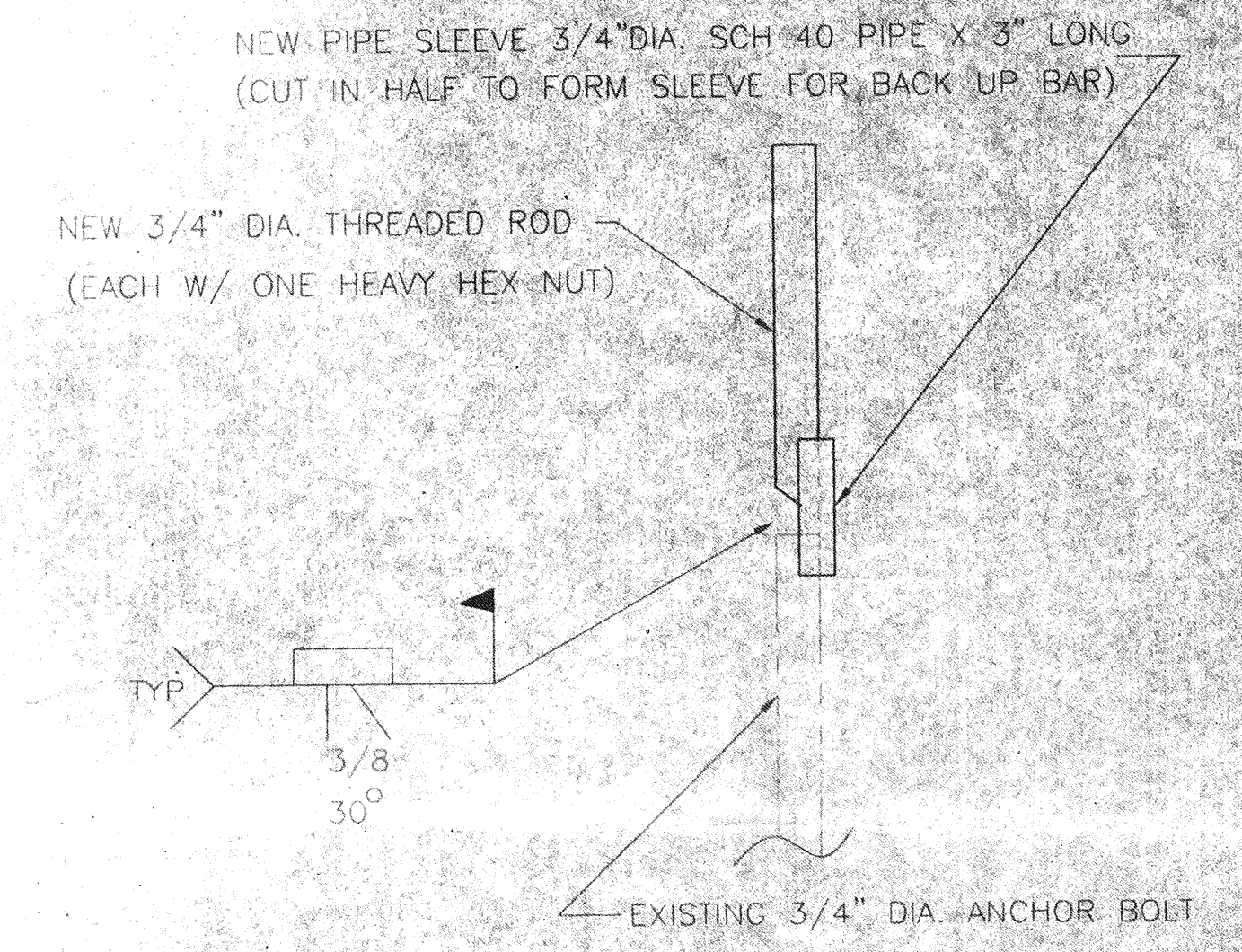

DETAIL "6"

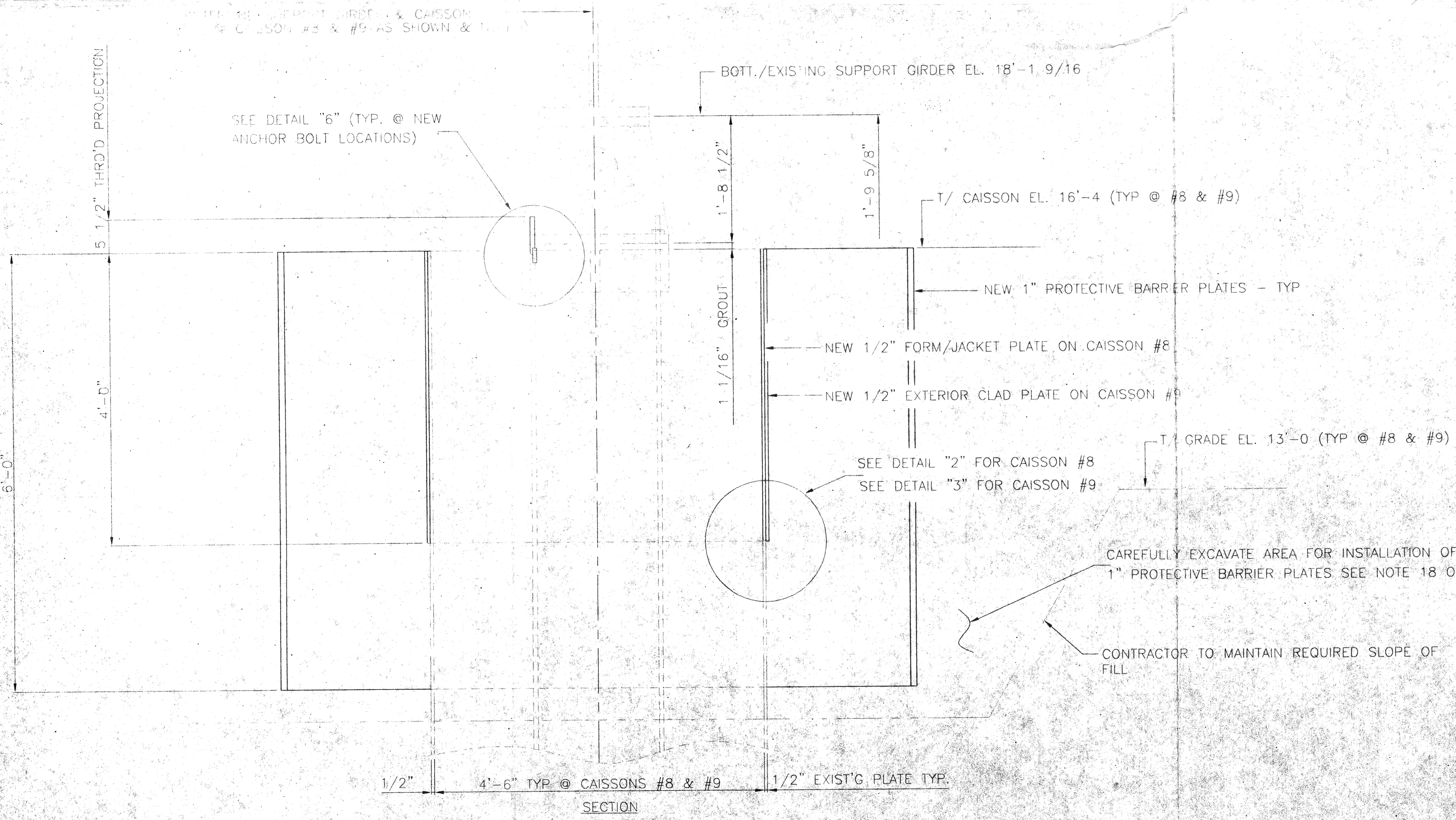

FOR CONSTRUCTION  
4 / 23 / 01

TOLERANCE EXCEPT AS NOTED  
FRAC. DIM ±  
DEC. DIM ±  
MIN. DIM ±  
ANGLES ±

NOTE: This drawing (or print) is the property of the Acme Steel Company, U.S.A. and shall not be traced, or reproduced in any manner, nor used for any purpose whatsoever except by written permission of Acme Steel Company.

DO NOT SCALE WORK TO DIMENSIONS

DR. MFM	CH. JMK	C-8765	REV.
SCALE NTS	APP.		

**ENSPECT, INC.**  
Engineering and Inspection Services  
8896 Louisiana Street, Merrillville, IN 46410  
Phone (219) 736-6002 Fax (219) 736-6003

REFERENCE DRAWINGS LISTED ABOVE  
**ACME STEEL COMPANY**

DATE: 4/01  
CHICAGO COKE PLANT  
PUSHING EMISSION SUPPORTS #8 & #9  
2001 INSPECTION AND REPAIRS

WORK THIS DRAWING WITH DRAWING C-8764